

32V, Synchronous, High-Efficiency, Boost PWM Controller with Programmable Output Current Limit

1 Features

- . 2.8V to 32V Supply Voltage Range
- . Integrated 2-A MOSFET Gate Drivers
- . External Soft Start (SS)
- . Pulse-Skip Mode under Light Loads
- . Dynamical programming of Output current and voltage using PWM signal or analog signal
- . Adjustable Switching Frequency using resistor
- . Frequency dithering for good EMI performance
- . Cycle-by-Cycle Peak Current Limit
- . Output Average Current Limiting with stable CC loop
- . Over-Voltage Protection (OVP)
- . Over-Temperature Protection (OTP)
- . Support NTC function
- . Programmable DCM and CCM
- . QFN4x4-32 Package

2 Applications

- . Backup Boosts
- . Start-stop Boosts
- . Bluetooth Speakers
- . USB Power Delivery

3 Description

The DPZ7130 adopts constant-on-time (COT) control topology, which provides fast transient response. The 2A gate driver minimizes the power loss of the external MOSFET while allowing the use of a wide variety of standard threshold devices. Additionally, the DPZ7130 uses pulse-skip mode to improve the efficiency under light loads or no load.

The switching frequency could be set to 150kHz, 300kHz based on different resistor value between FREQ pin and GND pin.

The device also features a programmable soft-start function and VADJ, IADJ pins are used to program output VBUS voltage and output current limit. Under-voltage lockout (UVLO), soft start (SS), an internal regulated supply, and slope compensation are all provided to minimize the external component count.

DPZ7130 provides voltage control loop, constant current loop. Protection features include hiccup mode for overload protection (OLP), over voltage protection (OVP).

4 Typical Application Schematic

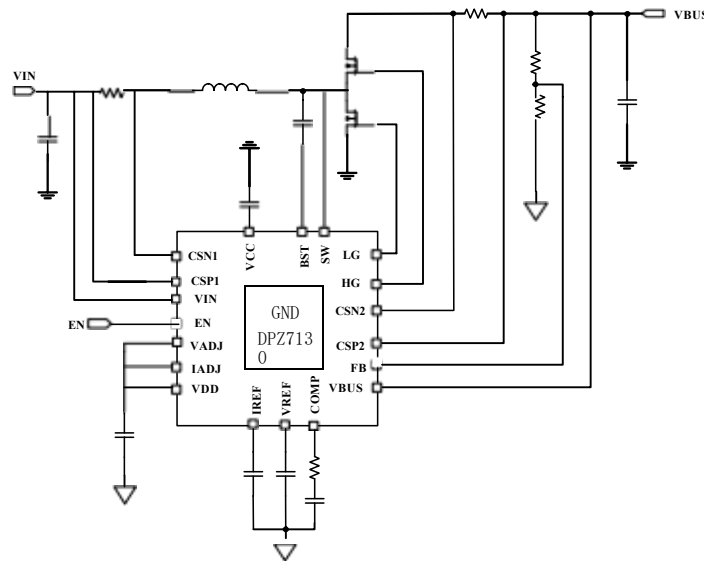

Fig. 1 Application Schematic

5 Pin Configuration and Functions

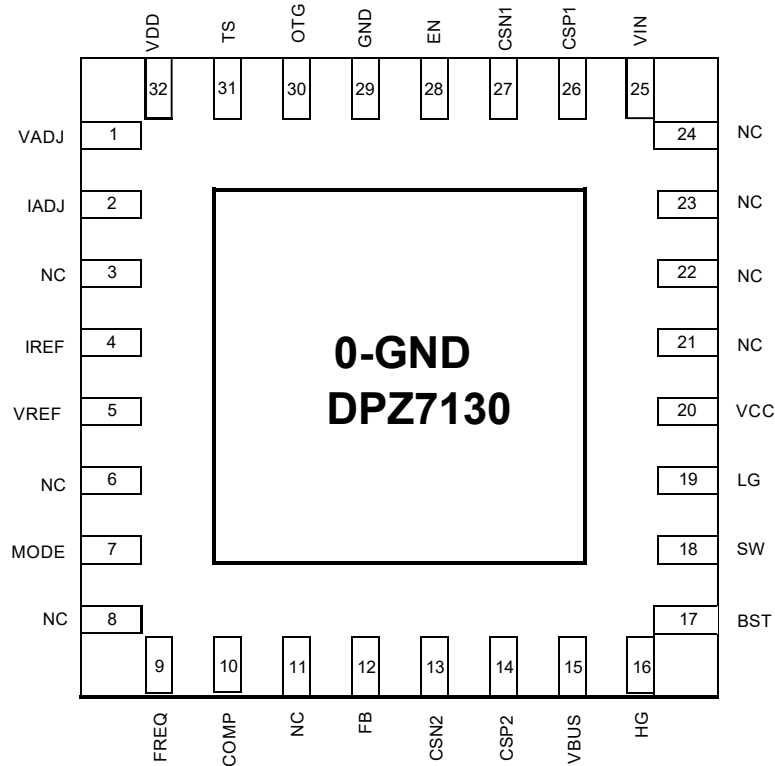

Fig. 2 Pin-Function (QFN4X4-32)

Pin		Description
Number	Name	
1	VADJ	Connect a 0-2V analog voltage or a PWM signal to program voltage reference on VREF pin. Connect this pin to VDD will force VREF to constant 2V.
2	IADJ	Connect a 0-2V analog voltage or a PWM signal to program voltage reference on IREF pin. Connect this pin to VDD will force IREF to 2V.
4	IREF	Reference voltage for input and output current limiting loop.
5	VREF	Voltage reference for voltage control loop.
7	MODE	CCM/DCM mode set pin. Float can set the part operates in DCM mode in light-load, connecting this pin to GND set the part operates in CCM mode. Mode is pulled high internally by a high value resistor.
9	FREQ	Connect to GND to set the switching frequency at 150kHz. Connect this pin to VDD to set switching frequency at 300kHz. It is recommended to use 150 KHZ.
10	COMP	Error Amplifier output.
12	FB	VBUS voltage feedback. Connect a resistor divider between VBUS and GND to FB to program VBUS voltage in battery discharging mode.
13	CSN2	The minus input of output current sense.
14	CSP2	The positive input of output current sense.
15	VBUS	VBUS voltage.
16	HG	High side MOSFET driver output.
17	BST	Boost pin for high side MOSFET driver.
18	SW	Connect this pin to the Switching point2 of the power stage.
19	LG	Low side MOSFET driver output2.
20	VCC	5.0V power supply for high side and low side driver
25	VIN	Input voltage.
26	CSP1	The minus input current sense.
27	CSN1	The positive input current sense.
28	EN	Logic High will enable the converter. Logic Low will disable the whole DPZ7130 . EN is pulled high internally by a high value resistor.

3/6/8/11/ 21/22/23/ 24	NC	Must leave them floating.
29/0	GND	Connect to GND.
30	OTG	Connect OTG to high.
31	TS	Connect to VDD pin.
32	VDD	5.4V power supply for DPZ7130control core.

6 Device Marking Information

Part Number	Order Information	Package	Package Qty	Top Marking
DPZ7130	DPZ7130IQN32	QFN4x4-32	4000	5700 RAAYMD

DPZ7130: Part Number

RAAYMD: RAA: LOT NO.; YMD: Package Date Code

7 Specifications

7.1 Absolute Maximum Ratings^(Note1)

PARAMETER	MIN	MAX	Unit
VIN, VBUS, CSP1, CSN1, CSP2, CSN2, SW	-0.3	40	V
BST to SW	-0.3	7	
VCC to GND	-0.3	7	
CSP1 to CSN1, CSP2 to CSN2	-0.3	0.6	
VBAT to CSP1, CSN1	-0.3	0.6	
VBUS to CSP2, CSN2	-0.3	0.6	
Other Pins to GND	-0.3	6	

7.2 Handling Ratings

PARAMETER	DEFINITION	MIN	MAX	UNIT
T _{ST}	Storage Temperature Range	-65	150	°C
T _J	Junction Temperature		+150	°C
T _L	Lead Temperature		+260	°C
V _{ESD}	HBM Human body model		2	kV

7.3 Recommended Operating Conditions^(Note 2)

	PARAMETER	MIN	MAX	Unit
Input Voltages	VIN , VBUS	2.8	32	V
Temperature	Operating junction temperature range, T _J	-40	+125	°C

7.4 Thermal Information^(Note 3)

Symbol	Description	QFN4x4-32	Unit
θ_{JA}	Junction to ambient thermal resistance	44	°C/W
θ_{JC}	Junction to case thermal resistance	9	

Notes:

- 1) Exceeding these ratings may damage the device.
- 2) The device function is not guaranteed outside of the recommended operating conditions.
- 3) Measured on approximately 1" square of 1 oz copper.

7.5 Electrical Characteristics (Typical at VIN = 7.4V, T_J =25°C, unless otherwise noted.)

Supply voltages	PARAMETER	CONDITION	MIN	TYP	MAX	UNIT
V _{IN}	V _{IN} voltage		2.8		32	V
I _Q	V _{IN} Shutdown Current	EN=0V, V _{IN} =7.4V		150		μA
V _{BUS}	Bus line voltage		2.8		32	V
V _{VCC}	Driver power supply voltage	V _{IN} =7.4V		5.0		V
V _{VDD}	Control core power supply voltage	V _{IN} =7.4V		5.4		V
UVLO/EN						
V _{IN_UV}	V _{IN} UVLO Rising			2.7		V
	UVLO Hysteresis			200		mV
V _{EN_UV}	Operation Threshold		1.1	1.2	1.3	V
	Hysteresis			200		mV
VREF						
V _{VREF}	VREF voltage	V _{ADJ} connected to V _{DD}		2		V
Control loop						
V _{FB}	V _{FB} regulation voltage	FB voltage		2		V
G _{mEA}	Error amplifier gm			450		μS
I _{SINK}	COMP sink/source current	V _{FB} =V _{REF} +100mV		15		μA
I _{SOURCE}	COMP source current	V _{FB} =V _{REF} -100mV		20		μA
I _{FB}	FB bias current	FB in regulation			100	nA
Frequency						
F _{SW}	Switching Frequency	FREQ 0-0.4V, short FREQ pin to GND.		150		KHz
		FREQ 1.8-5.4V, short FREQ pin to V _{DD} .		300		KHz
Current Limit						
I _{CC_LIM_BUS}	Bus average current Limit, V _{CSP2} - V _{CSP1}			40		mV
I _{CC_LIM_VIN}	Inductor peak current Limit, V _{CSP1} - V _{CSP1}			40		mV
NMOS Driver						
I _{HDRV} (Note 4)	Driver peak source current	V _{BST} -V _{SW} =5.0V		2		A
	Driver peak sink current	V _{BST} -V _{SW} =5.0V		2		A
I _{LDRV} (Note 4)	Driver peak source current	V _{CC} =5.0V		2		A
	Driver peak sink current	V _{CC} =5.0V		2		A
V _{BSTUV}	UVLO			2		V
	UVLO Hysteresis			300		mV
Output Protection						
V _{OVP}	Output over voltage threshold			110		%
V _{UVP}	Output under voltage threshold			50		%
V_{ADJ}, I_{ADJ}						
V _{TH_VADJ} (Note 4)	VPWM low voltage				0.4	V
	VPWM high voltage		2.5			V
V _{TH_IADJ} (Note 4)	IPWM low voltage				0.4	V
	IPWM high voltage		2.5			V
T _{SD} (Note 4)	Thermal Shutdown Threshold			150		°C
T _{HYS} (Note 4)	Thermal Shutdown Hysteresis			20		°C

Notes:

4) Guaranteed by design.

8 Typical Characterist

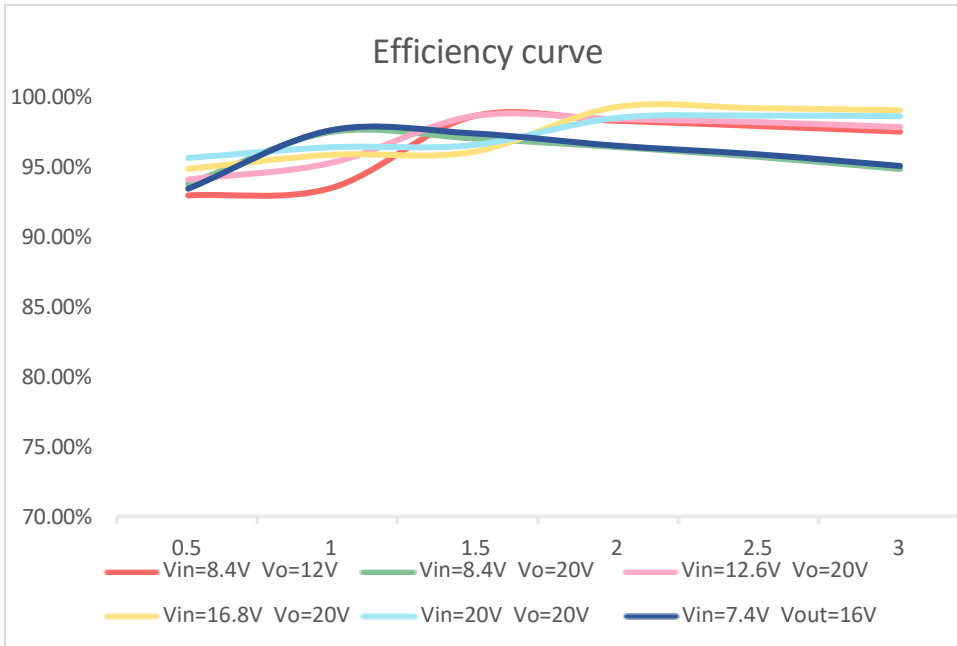
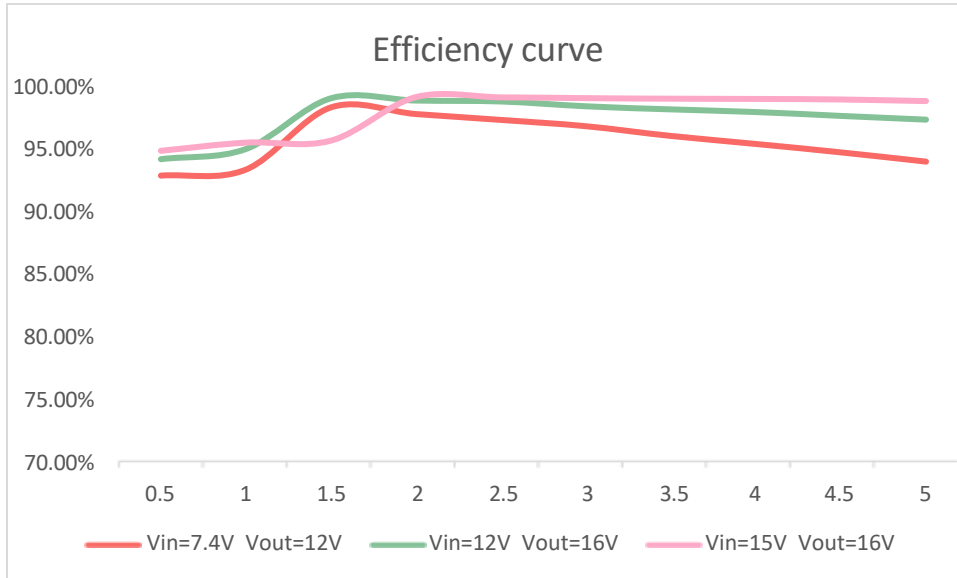

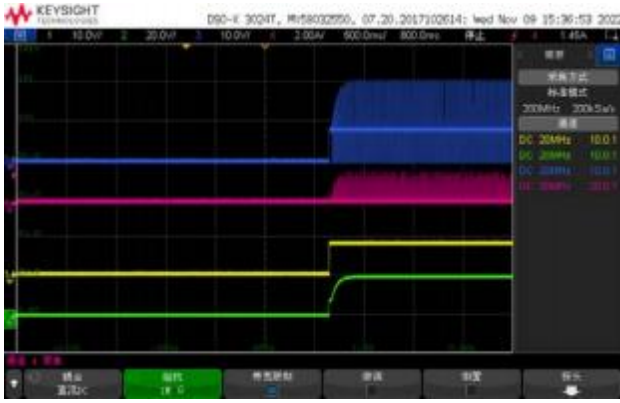

CH1: VIN CH2:VOUT CH3:SW CH4:IL
Vin=8.4V Vout=20V
Start up waveform through Vin, Iout =0A

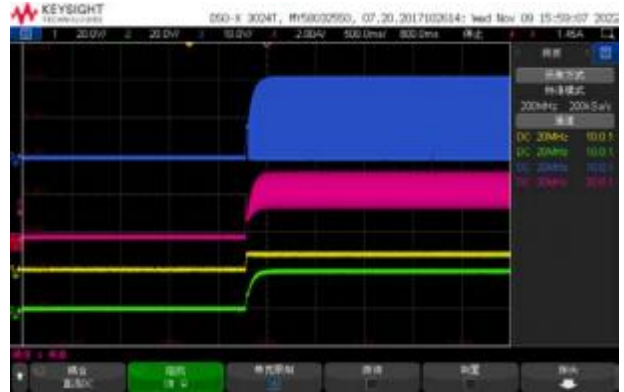

CH1: VIN CH2:VOUT CH3:SW CH4:IL
Vin=8.4V Vout=20V
Start up waveform through Vin, Iout =1A

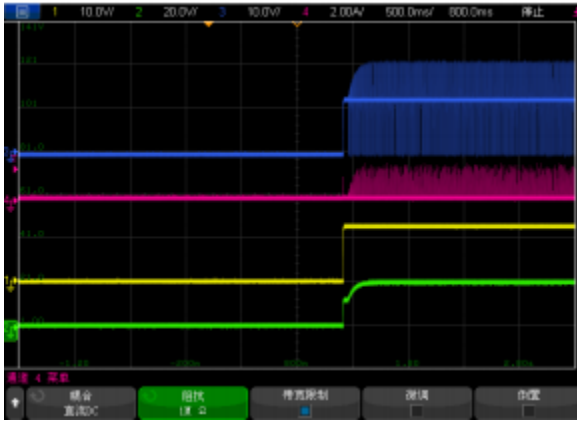

CH1: VIN CH2:VOUT CH3:SW CH4:IL
Vin=12.6V Vout=20V
Start up waveform through Vin, Iout =0A

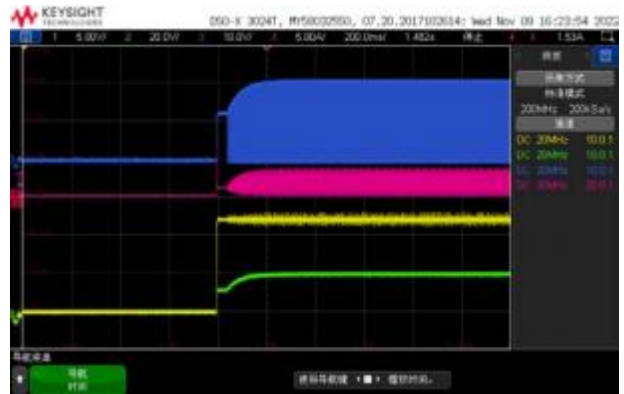

CH1: VIN CH2:VOUT CH3:SW CH4:IL
Vin=12.6V Vout=20V
Start up waveform through Vin, Iout =1A

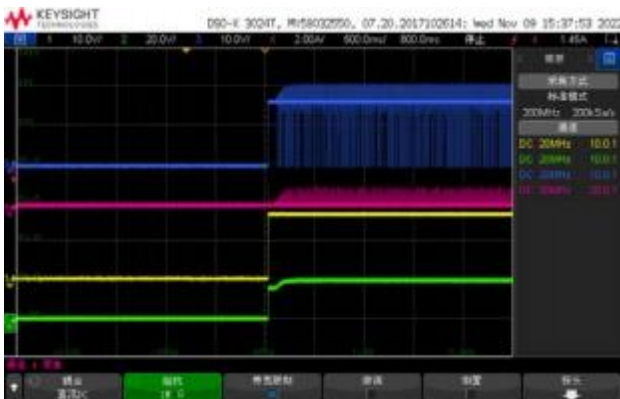

CH1: VIN CH2:VOUT CH3:SW CH4:IL
Vin=16.8V Vout=20V
Start up waveform through Vin, Iout =0A

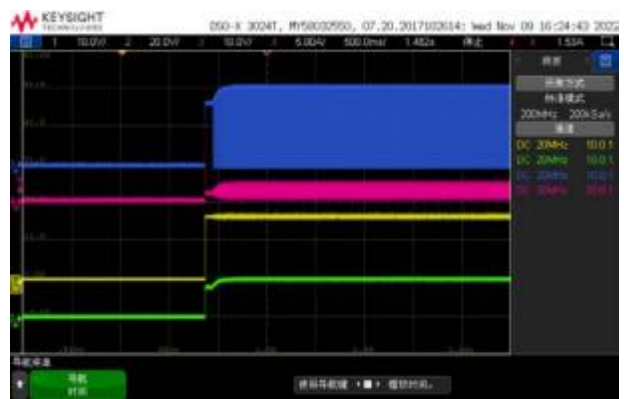

CH1: VIN CH2:VOUT CH3:SW CH4:IL
Vin=16.8V Vout=20V
Start up waveform through Vin, Iout =1A

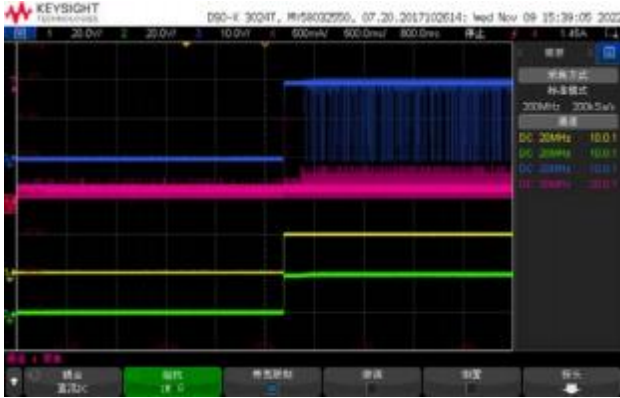

CH1: VIN CH2:VOUT CH3:SW CH4:IL

Vin=20V Vout=20V

Start up waveform through Vin, Iout =0A

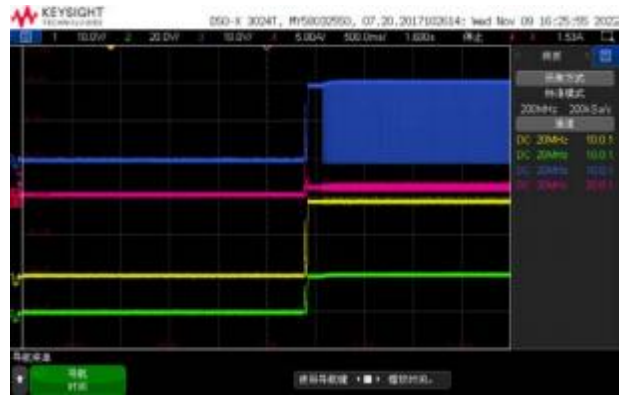

CH1: VIN CH2:VOUT CH3:SW CH4:IL

Vin=20V Vout=20V

Start up waveform through Vin, Iout =1A

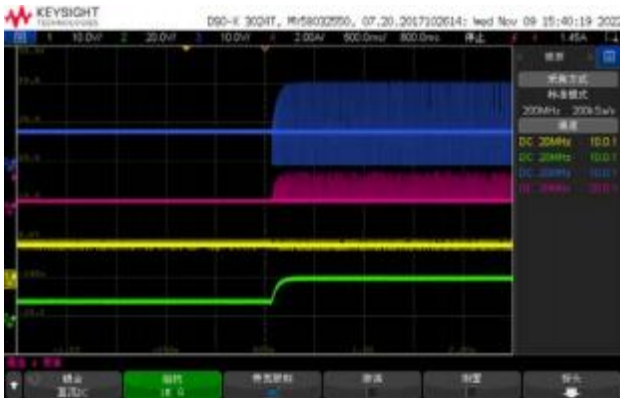

CH1: VIN CH2:VOUT CH3:SW CH4:IL

Vin=8.4V Vout=20V

Start up waveform through EN, Iout =0A



CH1: VIN CH2:VOUT CH3:SW CH4:IL

Vin=8.4V Vout=20V

Start up waveform through EN, Iout =1A

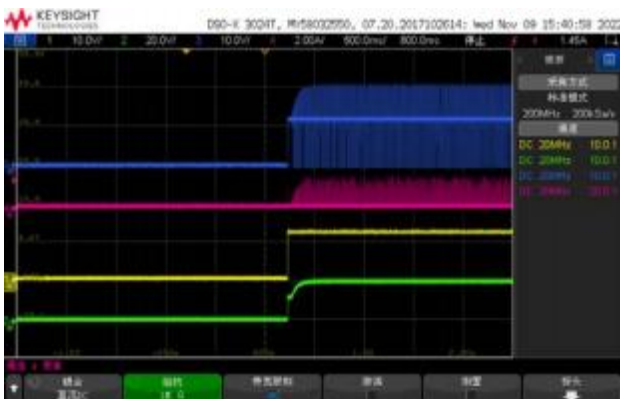

CH1: VIN CH2:VOUT CH3:SW CH4:IL

Vin=12.6V Vout=20V

Start up waveform through EN, Iout =0A



CH1: VIN CH2:VOUT CH3:SW CH4:IL

Vin=12.6V Vout=20V

Start up waveform through EN, Iout =1A

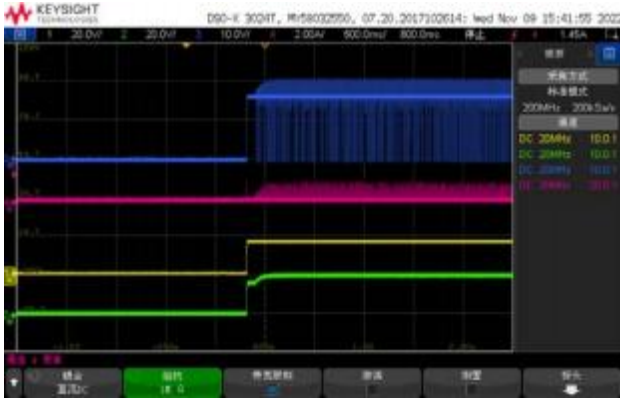

CH1: VIN CH2:VOUT CH3:SW CH4:IL
Vin=16.8V Vout=20V
Start up waveform through EN, Iout =0A



CH1: VIN CH2:VOUT CH3:SW CH4:IL
Vin=16.8V Vout=20V
Start up waveform through EN, Iout =1A



CH1: VIN CH2:VOUT CH3:SW CH4:IL
Vin=20V Vout=20V
Start up waveform through EN, Iout =0A



CH1: VIN CH2:VOUT CH3:SW CH4:IL
Vin=20V Vout=20V
Start up waveform through EN, Iout =1A

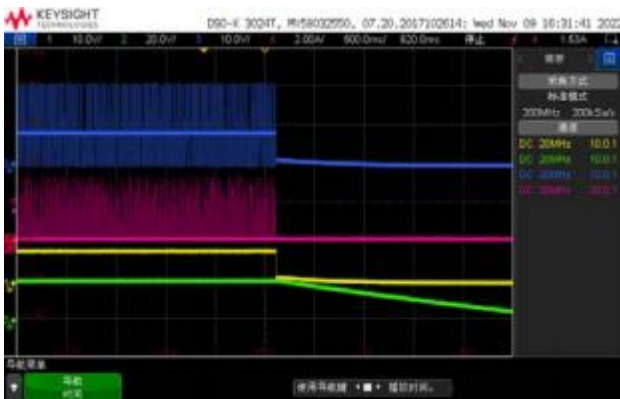

CH1: VIN CH2:VOUT CH3:SW CH4:IL
Vin=8.4V Vout=20V
Shut Down waveform through VIN, Iout =0A

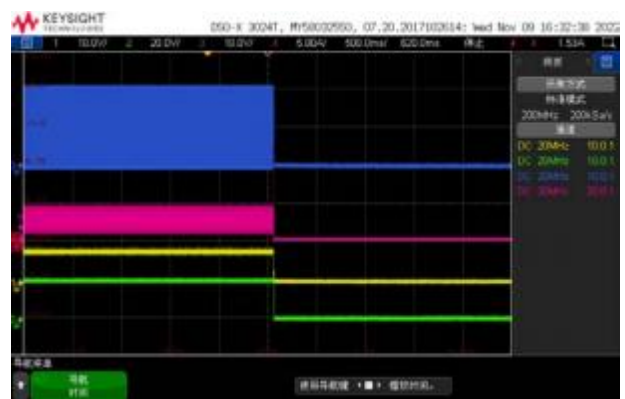

CH1: VIN CH2:VOUT CH3:SW CH4:IL
Vin=8.4V Vout=20V
Shut Down waveform through VIN, Iout =1A

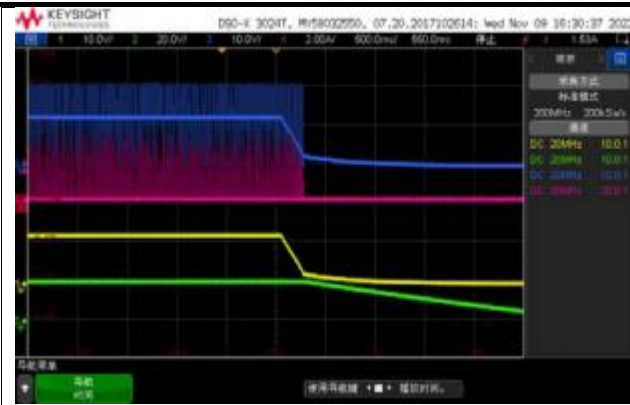

CH1: VIN CH2:VOUT CH3:SW CH4:IL

Vin=12.6V Vout=20V

Shut Down waveform through VIN, Iout =0A



CH1: VIN CH2:VOUT CH3:SW CH4:IL

Vin=12.6V Vout=20V

Shut Down waveform through VIN, Iout =1A

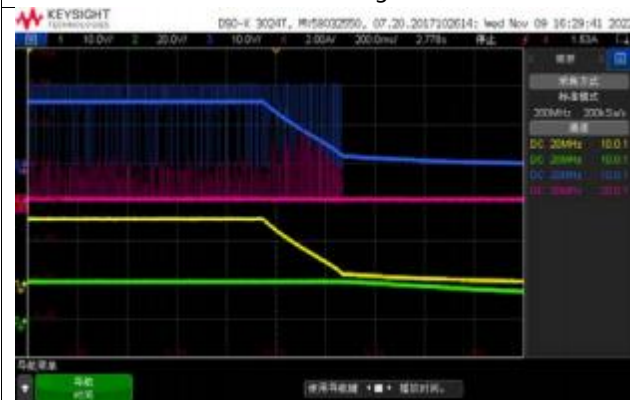

CH1: VIN CH2:VOUT CH3:SW CH4:IL

Vin=16.8V Vout=20V

Shut Down waveform through VIN, Iout =0A



CH1: VIN CH2:VOUT CH3:SW CH4:IL

Vin=16.8V Vout=20V

Shut Down waveform through VIN, Iout =1A



CH1: VIN CH2:VOUT CH3:SW CH4:IL

Vin=20V Vout=20V

Shut Down waveform through VIN, Iout =0A

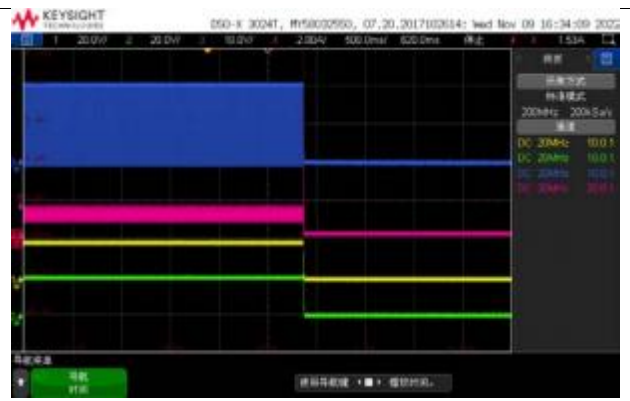

CH1: VIN CH2:VOUT CH3:SW CH4:IL

Vin=20V Vout=20V

Shut Down waveform through VIN, Iout =1A

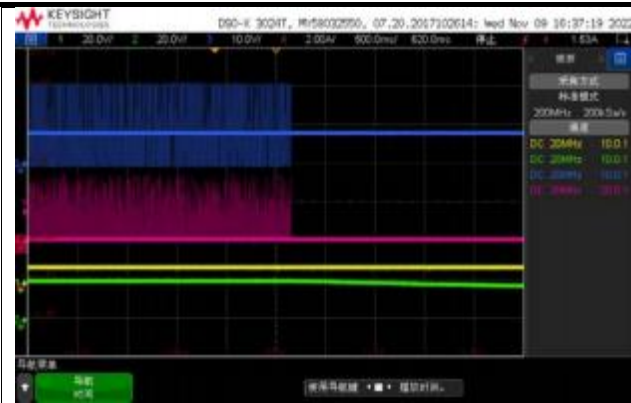

CH1: VIN CH2:VOUT CH3:SW CH4:IL

Vin=8.4V Vout=20V

Shut Down waveform through EN, Iout =0A

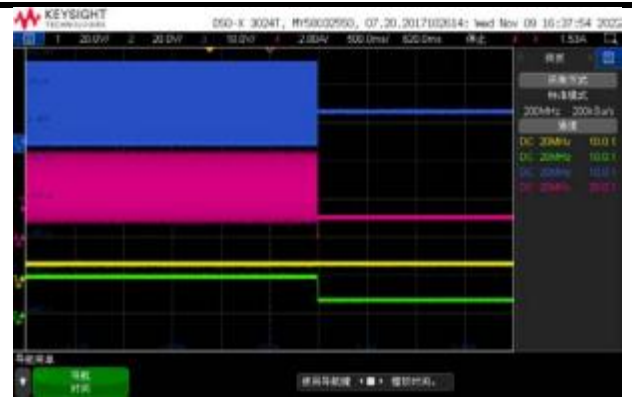

CH1: VIN CH2:VOUT CH3:SW CH4:IL

Vin=8.4V Vout=20V

Shut Down waveform through EN, Iout =1A



CH1: VIN CH2:VOUT CH3:SW CH4:IL

Vin=12.6V Vout=20V

Shut Down waveform through EN, Iout =0A

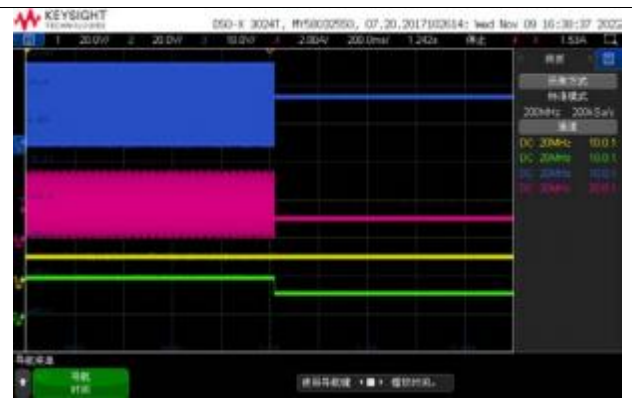

CH1: VIN CH2:VOUT CH3:SW CH4:IL

Vin=12.6V Vout=20V

Shut Down waveform through EN, Iout =1A



CH1: VIN CH2:VOUT CH3:SW CH4:IL

Vin=16.8V Vout=20V

Shut Down waveform through EN, Iout =0A



CH1: VIN CH2:VOUT CH3:SW CH4:IL

Vin=16.8V Vout=20V

Shut Down waveform through EN, Iout =1A



CH1: VIN CH2:VOUT CH3:SW CH4:IL
Vin=20V Vout=20V
Shut Down waveform through EN, Iout =0A



CH1: VIN CH2:VOUT CH3:SW CH4:IL
Vin=20V Vout=20V
Shut Down waveform through EN, Iout =1A

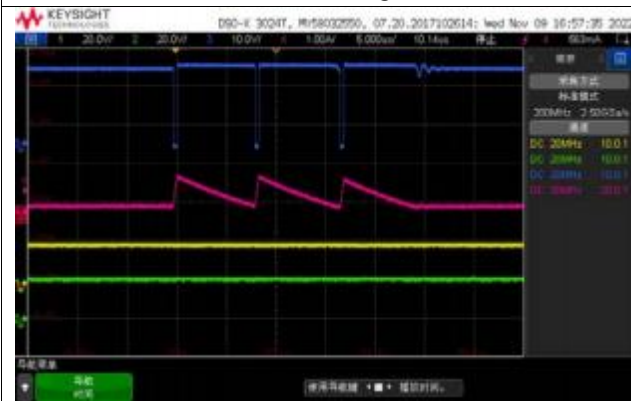

CH1: VIN CH2:VOUT CH3:SW CH4:IL
Vin=20V Vout=20V
Steady State waveform Iout =0A



CH1: VIN CH2:VOUT CH3:SW CH4:IL
Vin=20V Vout=20V
Steady State waveform Iout =1A

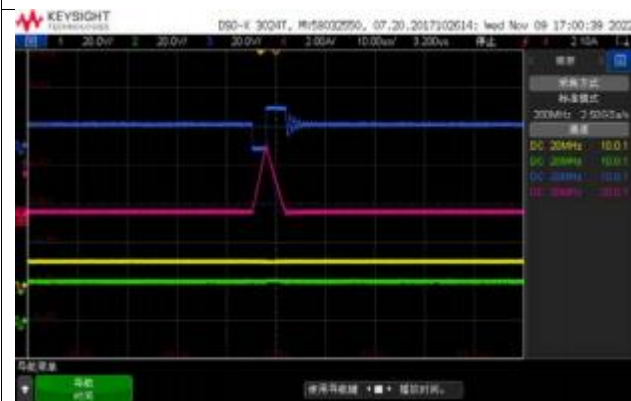

CH1: VIN CH2:VOUT CH3:SW CH4:IL
Vin=12.6V Vout=20V
Steady State waveform Iout =0A

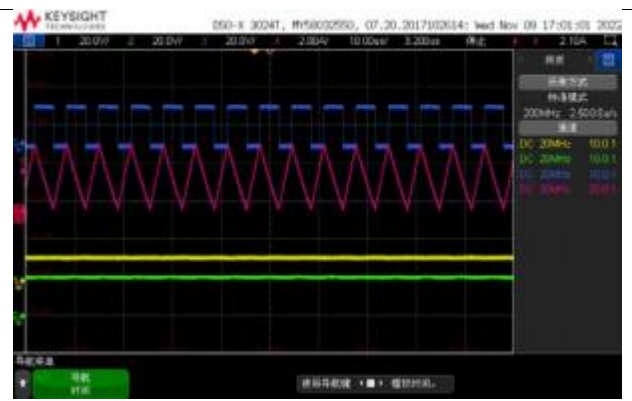

CH1: VIN CH2:VOUT CH3:SW CH4:IL
Vin=12.6V Vout=20V
Steady State waveform Iout =1A

9 Detailed Descriptions

9.1 Overview

The DPZ7130 is a Constant ON time control mode, PWM boost controller that can drive an external MOSFET capable of handling more than 10A of current, the integrated gate drivers peak current up to 2A. The switching frequency could be set to 150kHz, 300kHz based on different resistor value between FREQ pin and GND pin.

9.2 Enable/UVLO

When EN is greater than 1.2V operating threshold, the control loop starts to work and regulate output to target voltage. When EN pin is below the standby threshold (1.1V typical), DPZ7130 stops working. EN is pulled high to 4V internally using a 2Meg resistor.

9.3 Over current Protection and short circuit protection

DPZ7130 provides cycle-by-cycle peak current limit to protect against over current and short circuit conditions. When VOUT is drop to UV threshold, DPZ7130 will go into hiccup mode to lower down power consumption. If the short circuit condition is removed, the output voltage recovers after the new restart cycle begins.

For boost converters, there is no way to limit the current from the input to the output if the output experiences a short-circuit condition. Use a secondary protection circuit to protect the devices from these conditions.

9.4 Average Output Current Limiting

DPZ7130 provides optional average current limiting capability to limit the output current. The average current limiting circuit uses an additional current sense resistor connected in series with output voltage of the converter. A current sense gm amplifier with inputs at the CSP2 and CSN2 pins monitors the voltage across the sensing resistor and compares it with an internal 40 mV reference. If the drop across the sense resistor is greater than 40 mV, the gm amplifier regulates COMP voltage to lower down input or output current. The target constant current is given by Equation 1:

$$I_{CL(AVG)} = \frac{40 \text{ mV}}{R_{SNS}} \quad (1)$$

9.5 Frequency Setting (FREQ) and frequency dithering

DPZ7130 switching frequency can be programmed at 150 kHz, 300 kHz or 600 kHz and 1200 kHz by voltage at FREQ pin to GND. When FREQ is connected to AGND, the switching frequency is set at 150 kHz. When FREQ is connected to VDD, the switching frequency is set at 300 kHz.

9.6 Thermal Shutdown

DPZ7130 is protected by a thermal shutdown circuit that shuts down the device when the internal junction temperature exceeds 160°C (typical). The soft-start capacitor is discharged when thermal shutdown is triggered and the gate drivers are disabled. The converter automatically restarts when the junction temperature drops by the thermal shutdown hysteresis of 15°C below the thermal shutdown threshold.

9.7 VREF and IREF

VREF pin is the final reference voltage used in the voltage regulation loop. When VADJ is connected to VDD, VREF will be 2V. When VADJ is connected to a PWM signal, PWM signal will first be chopped to 2V and filter out using an internal resistor and external capacitor on VREF pin. The capacitor on VREF pin is also acting as soft-start capacitor at power up or in output voltage transition period. It is recommend using a relatively large capacitor such as 470nF for VREF pin and IREF pin.

The same mechanism works for IADJ and IREF pin.

10 Applications and Implementation

The typical application on the first page is a basic DPZ7130 application circuit. External component selection is driven by the load requirement, and begins with the selection of RS and the inductor value. Next, the power MOSFETs need to be selected. Finally, C_{IN} and C_{OUT} are selected. This circuit can be configured for operation up to an input voltage of 32V.

10.1 R_{CS} Selection

As shown in schematic diagram output current sense resistor RCS should be placed between the bulk capacitor for VBUS and the decoupling capacitor. A low pass filter formed by RF and CF is recommended to reduce the switching noise and stabilize the current loop. Place CSP/CSN, symmetrically and keep them away switching signals such as BST, SW, VIN, VBUS etc.

10.2 Inductor Selection

The operating frequency and inductor selection are interrelated in that higher operating frequencies allow the use of smaller inductor and capacitor values. The inductor value has a direct effect on ripple current. The inductor current ripple ΔL is typically set to 20% to 40% of the maximum inductor current in the boost region at V_{IN(MIN)}.

For a given ripple, the inductance terms in continuous mode are as follows:

$$L > \frac{V_{IN(MIN)}^2 (V_O - V_{IN(MIN)}) * 1000}{f * \Delta I * V_{OUT}^2} \text{ uH} \quad (3)$$

where: f is operating frequency, kHz

V_{IN(MIN)} is minimum input voltage, V

V_{IN(MAX)} is maximum input voltage, V

V_{OUT} is output voltage, V

ΔL is maximum inductor ripple current, A, usually select 20~40% maximum output current.

For high efficiency, choose an inductor with low core loss, such as ferrite. Also, the inductor should have low DC resistance to reduce the I²R losses, and must be able to handle the peak inductor current without saturating. To minimize radiated noise, use a toroid, pot core or shielded bobbin inductor.

10.3 C_{IN} and C_{OUT} Selection

The C_{OUT} must be capable of reducing the output voltage ripple because of the discontinuous output current. The effects of ESR (equivalent series resistance) and the bulk capacitance must be considered when choosing the right capacitor for a given output ripple voltage. The steady ripple due to charging and discharging the bulk capacitance is given by:

$$\Delta V_{(Cap)} = \frac{I_{OUT(MAX)} * (V_{OUT} - V_{IN(MIN)})}{C_{OUT}} \text{ V} \quad (4)$$

where C_{OUT} is the output filter capacitor.

The steady ripple due to the voltage drop across the ESR is given by:

$$\Delta V_{(ESR)} = I_{OUT(MAX,BOOST)} * ESR \quad (5)$$

10.4 Output voltage setting

The DPZ7130 output voltage is set by an external feedback resistive divider carefully placed across the output capacitor. The 1% resistance accuracy of this resistor divider is preferred. The resultant feedback signal is compared with the internal precision 2V voltage reference by the error amplifier. The output voltage is given by the equation:

$$V_{OUT} = 2V * \left(1 + \frac{R_1}{R_2}\right) \quad (6)$$

Where R₁ is the upper resistor and R₂ is the lower resistor in the feedback network.

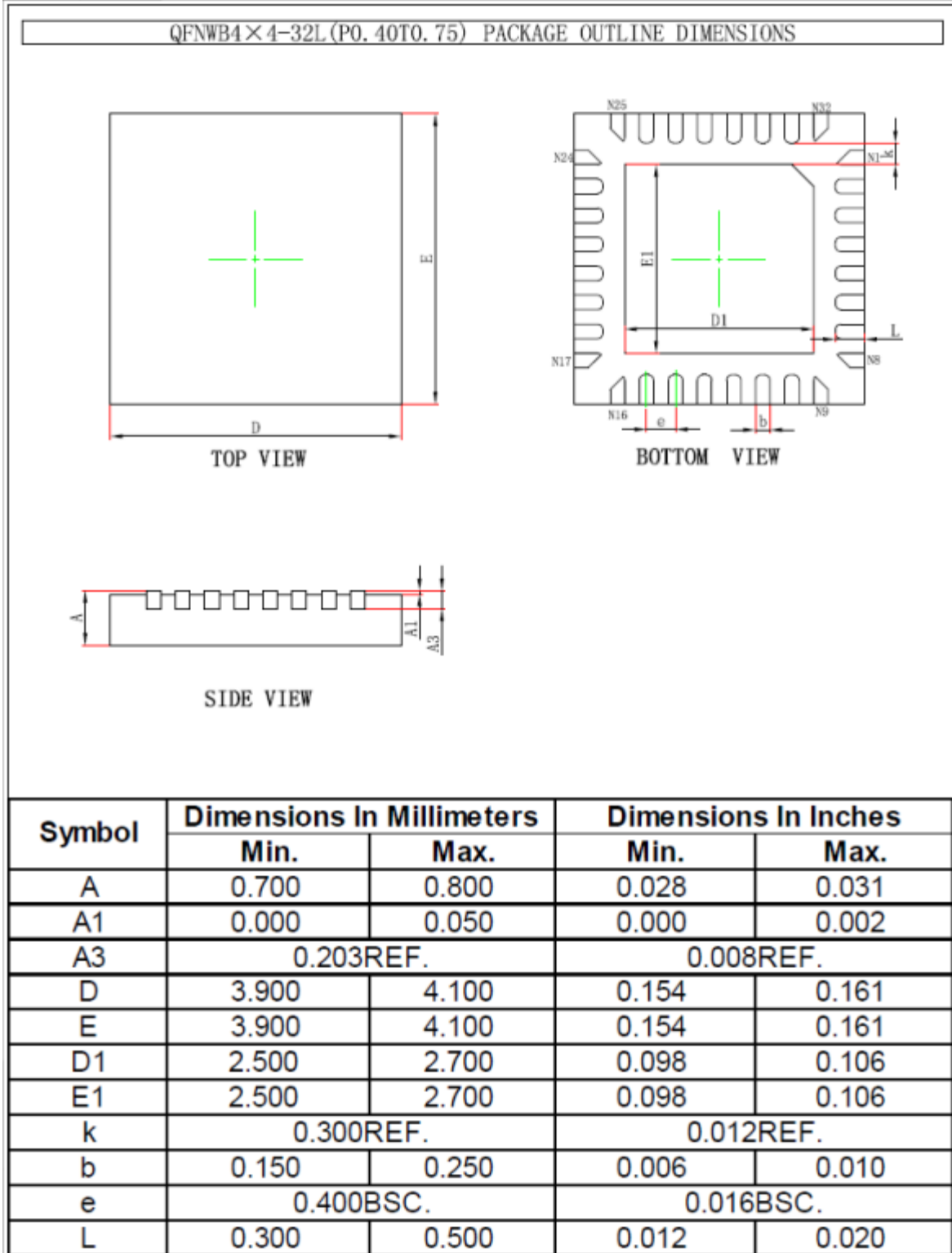
12 Packaging Information

IMPORTANT NOTICE

Powlicon Inc. assumes no responsibility for any error which may appear in this document. Powlicon Inc. reserves the right to change devices or specifications detailed herein at any time without notice. Powlicon Inc. does not assume any liability arising out of the application or use of any product described herein; neither it does it convey any license under its patent rights, nor the rights of others. Powlicon Inc. products are not authorized for use as critical components in life support devices or systems without written approval letter from the Chief Executive Officer of Powlicon Inc. The use of products in such applications shall assume all risks of such use and will agree to not hold against Powlicon Inc. for any damage.